

## What is Hot Tapping?



A Hot Tap is defined as using a drilling machine to cut a hole into an in-service, under-pressure piping system. This is done without service interruption or product leakage. Typical applications of a Hot Tap include making a branch connection, initiating a bypass and allowing performance of a Line Stop. Components required to perform a Hot Tap normally include a fitting designed to contain system pressure, a valve used to control the new connection and a drilling or tapping machine.

Hot/Wet/Cold Tap and Line Stopping/Plugging services allow our client to modify, maintain and repair pressurized systems with no interruption of production. As a recognized leader in the Hot/Wet/Cold Tapping and Line Stopping/Plugging services business, EA Services strives to provide the highest level of customer satisfaction to the water and waste water, commercial building, industrial piping, process facilities, mining, power generation, paper, pulp, refining, petrochemical, liquid and gas transmission pipelines and offshore markets. Our equipment and service technicians are prepared to meet any challenge whether it be emergency, planned or routine maintenance activities of our clients.

## Hot Tap Capabilities

- Available in size ranges 1/2 inch through 60 inch diameter cut sizes and a boring bar stroke (reach) of over 120 inches.
- Available off the shelf for up to 1480 psig maximum operating pressure and temperatures as high as 500° F. Custom designs and packers offered for higher system requirements.
- Power driven with pneumatic or hydraulic drives featuring a new level of sophistication and dependability.
- Complete dimensional compatibility with industry standards of consumables and equipment. This means that most other major brands of cutters, pilot drills, holders, adapters, etc. will also fit onto our new generation of equipment.
- Install pig sigs and thermowells.

Hot tapping is a process of cutting holes into pipe, tanks, or any pressurized vessel without interrupting system function and with no release or loss of product. Hot taps permit new tie-ins to existing systems, the insertion of devices into the flow stream, permanent or temporary bypasses, and are the preparatory stage for line plugging.

**Angle hot tapping:** This procedure refers to any hot tap where the centerline of the tapping nozzle is not perpendicular to the surface being tapped. Before welding, contact EA Services to discuss degree of angulation and the possible need for a centering device to stabilize the pilot drill. We are currently equipped to perform angle taps in sizes 1" through 24", as much as 45° off perpendicular, and into the heel of short or long radius ells.

**Tapping blind flanges and heavy-wall vessels:** Hot tapping heavy-wall vessels and blind flanges is not a problem, provided special issues are addressed in the design of the branch connection. Please consult EA Services prior to welding to discuss these considerations.

**Tapping materials other than carbon steel:** In addition to carbon steel, we commonly tap cement lined pipe, transite, cast iron, stainless steel and other alloys, plastic and fiberglass. Although we tap these materials frequently, additional information such as the thickness and composition of linings, hardness of alloys, or type of fitting and valve through which we will be operating may be needed to insure that proper equipment is provided for your job.

**Tapping materials that can not be welded:** If it is necessary to tap or plug a line that cannot be welded, such as cast iron, transite, or even carbon steel in an area where welding is not permitted, a bolt-on tapping or plugging

fitting can be provided. EA Services offers mechanical fittings by several quality manufacturers, giving us the latitude to provide the right fitting at the right price and delivery for your job. If a standard product does not suit your application, one can be custom fabricated that will meet your needs.

## Hot Tap Photos



*Hot Tap in Manufacturing Plant*



*7 1/2" Hot Tap in Industrial Manufacturing Plant*



*Performing 54" Hot Tap*



4" Hot Tap



Angle Tap



## Leak Sealing Services

EA Services provides routine and emergency on-stream, on-line, leak repair. Leak sealing solutions for water, air, process and steam leaks. EA Services provides our clients with engineered, innovative solutions for temperatures ranging from cryogenic to 1100°F, and pressures from vacuum to 1000 psig. Our leak repair services are supported by a staff of on call design engineers, decades of experience, proven sealants and packing, written procedures, and some of the most experienced and talented Field Technicians and Supervisors in the industry. At EA Services, we strive to provide the most cost effective and reliable leak repair solution to meet the needs of our clients. Whether it is a band clamp repair, a wire wrap of a flange or bonnet, a stock clamp or enclosure or a custom engineered solution, we offer the right repair to solve your problem fast.

## Typical Applications

:

- Valve Packing Leaks »
- Flange Leak Repair »
- Piping System Leaks »

## Valve Packing Leaks

### Drill and Tap Valve Packing Injections and Restoration



*Drill and Tap Valve Injection*

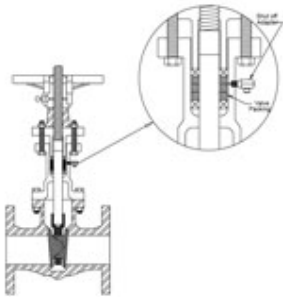

*Before - Steam Leak on Valve Packing*



After - Repaired Steam Leak on Valve Packing

[Back to Top](#)

## Flange Leak Repair Wire Wrap

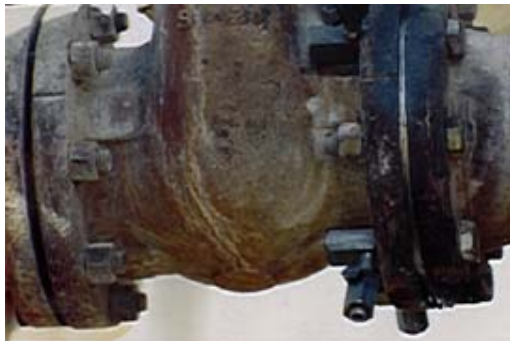

Wire Wrap on Valve end Flange

"...the most cost effective, off the truck repair to flange and bonnet leaks."

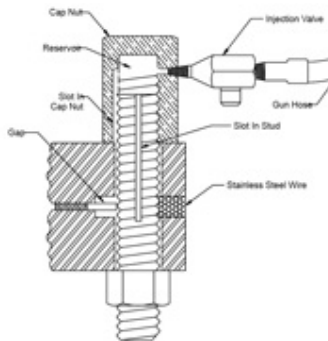

Wire Wrap with Cap-nut Injection on Flange Leak

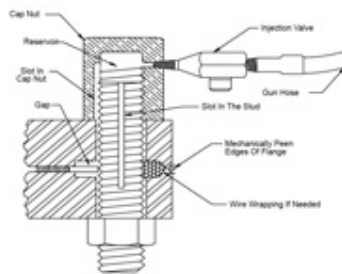

Wire Wrap with Peened Flange Gap Over Wire

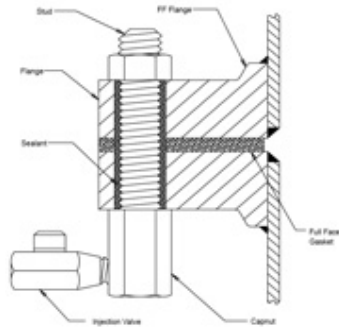

Cap-nut Injection on Full Faced Flange Leak

## Flange Clamps



Flange Clamps

"...designed to solve even the most aggressive leaks to flanges and bonnets."

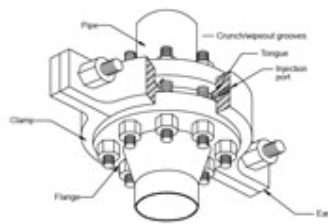

Flange Clamp with Crunch Teeth Tongue

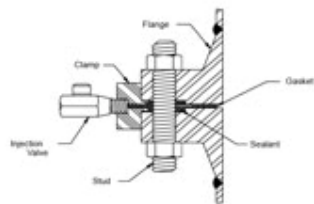

Flange Clamp with Crunch Teeth Tongue

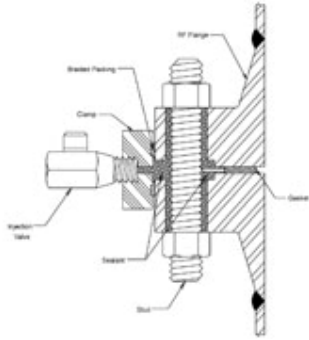

*Flange O.D. Clamp with Packing Seal*

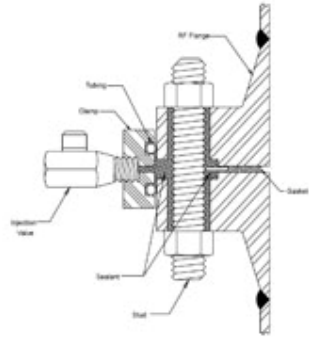

*Flange O.D. Clamp with Tubing Seal*

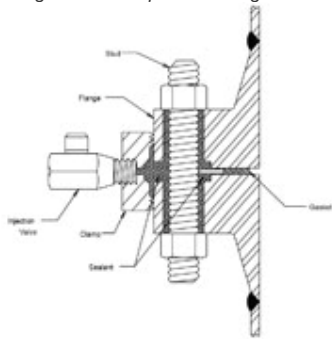

*Flange O.D. Clamp with Crunch Teeth Seal*

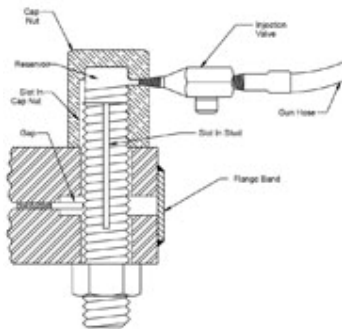

*Band Clamp with Cap-nut Stud Injection*

[Back to Top](#)

## Piping System Leaks

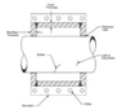

*Perimeter Seal Pipe Enclosure*

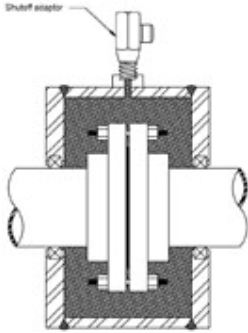

*Packing Seal Perimeter Box Enclosure*

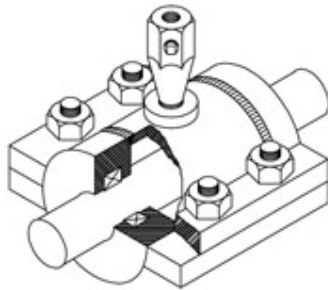

*Packing Seal Pipe Enclosure*



*Piping System Leaks*

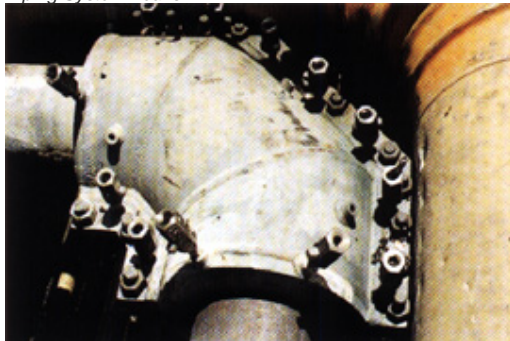

*ELL Enclosure*





*Packing Seal Perimeter Enclosure*

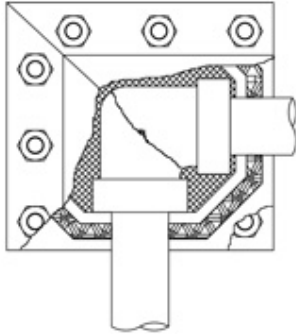

*1 • Ell Enclosure*

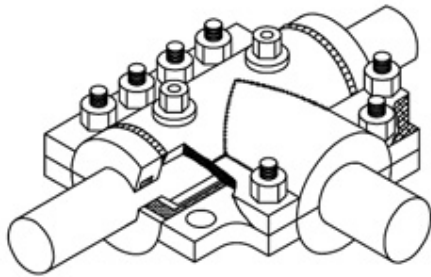

*Tee Enclosure*

"...a repair solution for every shape and size, designed to provide the most cost effective solution to meet the client needs."

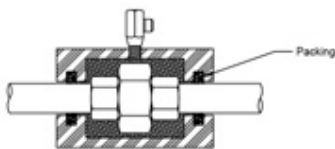

*Packing Seal Perimeter Enclosure*

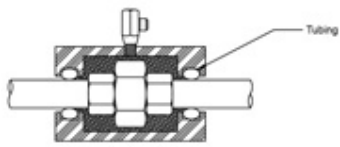

*Tubing Seal Perimeter Enclosure*

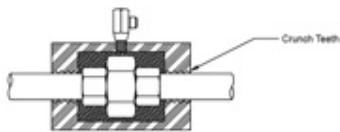

*Crunch Teeth Seal Perimeter Enclosure*

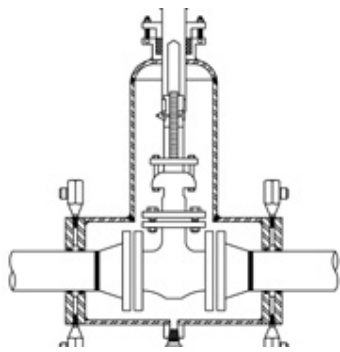

*Valve Enclosure with Perimeter Seal*

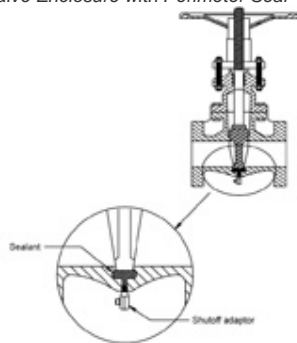

*Valve Seat Kill*

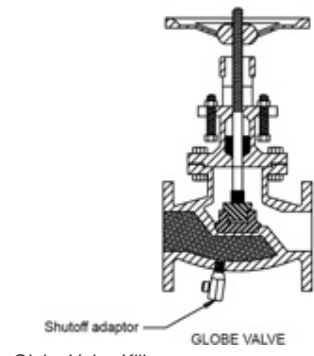

*Globe Valve Kill*

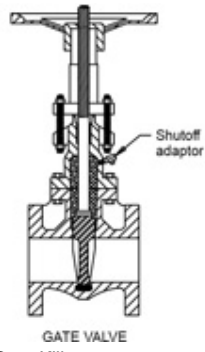

*Valve Gate Kill*

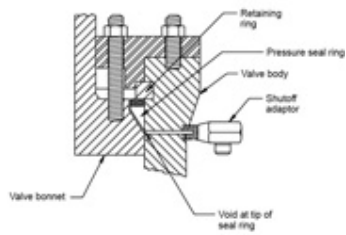

*Pressure Seal Injection*



*Custom Engineered Leak Repair Solutions*

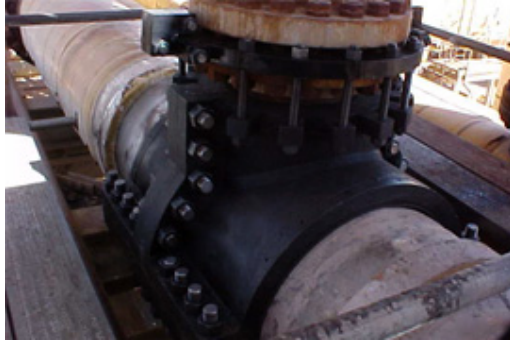

*Custom Engineered Leak Repair Solutions*



## Hot Tapping and Line Stopping Services

EA Services is a recognized leader in the Hot Tapping and Line Stopping industry. EA provides standard design off-the-shelf equipment to perform Hot Taps from 1/2 inch to 60 inches and Line Stops from 1/2 inch to 60 inches. We strive to provide the highest level of customer satisfaction through service and pride ourselves on performing under the most challenging circumstances.

## Typical Hot Tap and Line Stop Applications

- [Hot Tap »](#)

- [Line Stop »](#)
- [Stock Fitting »](#)



## Composite Wrap Services

Stop and repair external corrosion, dents, gouges, erosion, or other defects in piping systems with EA Services field applied composite solutions. Restore piping systems to their Maximum Allowable Operating Pressure (MAOP) regardless of surface irregularities (welds, dents, sleeves etc) piping configuration (tees, ells, reducers) internal or external wall loss. Complete and permanent repairs can also be made to vessels, tanks, welds, and infrastructure components such as bridge columns, pilings, and poles. EA Services composite wrap systems meet the engineering design requirements of DOT, ASME B31.4/31.8, and ASME PCC-2 and provide our clients with a permanent repair alternative to welded sleeves, bolt on repair clamps and or pipe replacement. The EA Services Composite Wrap for pipeline repairs allow plant owners and operators to restore corroded or eroded pipe and piping systems to original design without the expense and hassle of extended down-times.

The structural system forms a pipe around a pipe, and each successive wrap increases the pressure rating. Its bidirectional weave allows for strength in both the hoop and axial directions experiencing little or no creep properties over time, ensuring that there is no reduction in strength. EA Services Composite Wrap low profile repair can be installed on tees, elbows, straight runs of pipe, confined spaces and irregular surfaces that require structural reinforcement or leak containment. The adhesive properties of the epoxy allow wrap systems to be applied to most substrates.

## Typical Applications

- [Dented Repairs »](#)
- [Cracked Repairs »](#)
- [Corroded Repairs »](#)
- [Subsea / Underwater Repairs »](#)
- Stop corrosion
- Prevent corrosion.
- Save time, labor and equipment cost
- Extend the service life of piping and infrastructure
- Reduce or eliminate downtime
- Improve safety
- All pipe sizes, repair any size column, piling or tank.
- Compatible with Carbon, stainless, alloys, PVC fiberglass and more
- No VOCs
- Wrapped while the line is in service
- No line evacuation
- No welding of pipe
- No need to cut the pipe
- Applied to chemical, hot and volatile systems

- DOT and ASME compliant

## Dented Repairs



*Repair of Dented Pipeline*



*Repair of Dented Pipeline*



*Dented and cracked pipe*



*Dented pipe*



*Dented and cracked pipe repaired with composite wrap*



*Dented Pipe*



*Dented Pipe repaired with Composites*

## **Cracked Repairs**



*Repair of 4" Cracked Tee*



*Repair of "Out of Round" Pipeline with Composites and Repair Sleeve*







## Corroded Repairs



*Repair of Corroded Transmission Pipeline*



*Repair Over Corroded Weld on Pipe*



*Repair of Corroded Service Pipe*



*Repair of Corroded Service Pipe*



*Repair of Corroded Service Pipe*



*Pitted Pipe*



*Repair of Pitted Pipe*



*Corroded 4" Water Line*



*Repair of Corroded Water Line*



*Corroded Service Line*



*Repair of Corroded Pipe*



*Corroded 14" effluent Water Line*



*Corroded 14" effluent Water Line Repaired with composites*



*Composite repair of bridge support*





*Repair of corroded 4" crude oil line over weld*

### **Subsea / Under Water Repairs**

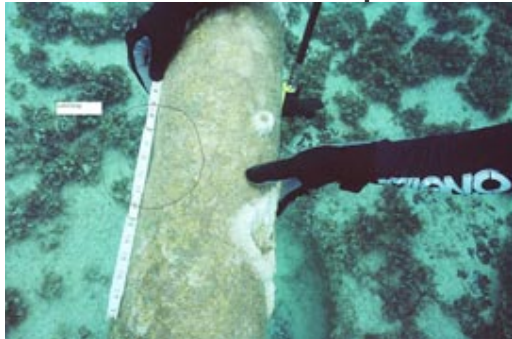

*Close up of Damage*



*Cleaning the Dented Location*



*Close up of Dent*

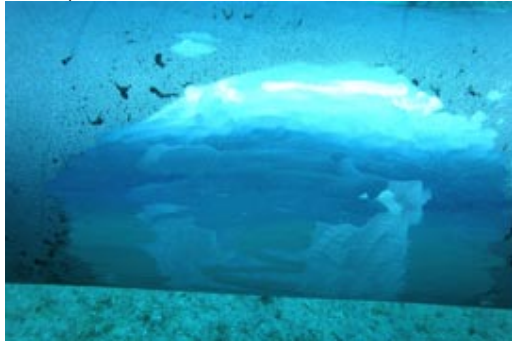

*Pipe Prep*



*Pipe after 1st Lay-up of Composite*



*After 2nd Lay-up of Composite*



*Finished Repair*



*Everything is OK*

## Field Machining Services

EA Services provides highly trained and experienced machining technicians along with the best portable machining equipment that is available today. We perform all aspects of in-place/On-site machining including pipe cutting & beveling, flange facing, milling, boring, shaft turning, grinding, drilling and tapping. We are prepared to provide our services for any scheduled construction or maintenance projects and are also available 24 hours a day, seven days a week 360 day a year to respond to your emergency needs.

Our field technicians & branch staff have years of field machining experience and will help assure that your projects get completed quickly and correctly. We have the experience to be creative, cost effective, and anticipate problems before they happen.

- Pipe Cutting and Beveling
- Flange Facing
- Boring
- Milling
- Shaft and Journal Turning



## Pipe Cutting & Beveling

EA Services performs pipe cutting (severing) and beveling on diameters 1/2" through 120" of any wall thickness. We have the capability to machine all materials including carbon steel, stainless steel, chrome, P91 and exotic alloys.

We can provide equipment & tooling to machine weld joints to your specifications. Standard bevels, compound bevels, J-bevels and other configurations are easily achieved.

When required we will counter bore the piping, valves or fittings to assure exact weld joint match ups for better weld results. Taper boring or schedule reduction to match pipe ends of different wall thickness is not a problem.

A wide range of portable machining tools allow us the option to mount and machine a variety of valves, fitting and other components. Our extensive equipment inventory also means we can work in areas that have minimal radial and axial clearances.

## Flange Facing

We have the capability of machining flanges up to 120" OD. EA Services routinely machines raised face, RTJ and tongue & groove flanges. Gasket surfaces on exchanger heads, Exchanger diaphragm removal, dollar plates, tube sheets and vessel shells are a specialty. We also are experienced in machining of gasket surfaces on nozzles, man ways and hand holes. We offer equipment that requires low axial and radial clearance envelopes. Any surface finish requirement can be met.

## Milling

We have a large inventory of milling machines that will fit varying applications. Pump and motor bases are routine projects for us & are machined to your tolerances quickly and accurately. We also provide milling of other items such as dividers and exchangers, key ways in shafts and gasket surfaces on access doors. Tight tolerances and exact surface finishes are assured.

## Shaft and Journal Turning

EA Services can turn shafts from 2" through 22" outside diameter. We can machine o-ring grooves, repair bearing surfaces, cut out of round gear seats and re-size shaft ends. Our machining methods & equipment used require only minimal disassembly of your equipment. There is no need for the shaft to rotate during the machining process. Our technicians will hold the tightest of tolerances and leave the exact surface finish required.

## Field Machining Photos



*Counter bore & bevel on pipe spool using clamshell*



*Re-machining gasket surface of tube sheet using OD mount flange facer*





*Re-machining access door of tank*



*In place machining of shaft bearing surface*



*Boring header nozzle flange with 1" boring bar*



*Milling of partition groove on exchanger dollar plate.*

## Concrete Restoration Services

EA services concrete repair division is developing products and techniques that address the changing production demands of our customers. Products that return a floor to a client quickly with no production impact are imperative. Methods and products that are environmentally friendly are desired and requested. Whether it's a dust free preparation method near a clean room or it involves a field applied structural composite reinforcement, EA has become a go to "solutions provider" for an ever changing industrial environment.

## Typical Applications

- [Chemical and Refining »](#)
- [City & Municipalities »](#)
- [OEM / High Tech / DOT »](#)
- [Painting & Blasting »](#)
- [Public utilities »](#)
- [Pulp & Paper »](#)



## Chemical and Refining

EA Services is a known leader in the coatings industry and is committed to continue to provide our customers with the latest coatings technology to meet the stringent needs of our customers.

- Chemical Containments Coatings
- Containment Repairs (Structural)
- Crack Injection (Pressure Injection)
- Concrete Overlays
- Cooling Tower Coatings
- Non Skid Coatings
- Chemical Loading / Unloading Pads
- Tank lining
- Clarifier Coatings
- Warehouse Floors
- Shower / Restroom Floor Coatings Decorative and Non Decorative

## Photo Examples



---

City & Municipalities



All facilities are unique, whether it is a Correctional, Healthcare, Education, Wastewater treatment plant. Most facilities are occupied when applying coatings and need to have low VOC's. EA Services provides products to withstand wear and abuse for many years along with being aesthetically pleasing.

Primary areas such as halls, operating rooms, classrooms, laboratories, treatment rooms, cells, pools have special requirements. Loading docks, cafeterias and exterior substrates can also present special challenges. Many facilities have multiple buildings on site including power plants, parking garages.

It is critical to have products that produce minimal to no odor and low to zero VOC's. Also, products need to cure and dry quickly and last for many years. EA Services can provide you with those products.

## Before & After Examples



*Before*



*After*



*Before*



*After*



*Before*



*After*



*Before*



*After*

---

## **OEM / High Tech / DOT**

Protecting the floors in the manufacturing facilities has changed over the past 20 years. It is imperative to keep the plant running at maximum efficiency for maximum profits. Unscheduled down times can cause millions of dollars in lost revenue.

Areas such as secondary containment, assembly floor areas, and aircraft hangers need to be protected and aesthetically pleasing. This is where EA Services can help.

EA Services offers a wide variety of products to meet our customer's needs, such as non skid coatings, chemical resistant coatings, decorative and non-decorative, along with many others. No matter what the application, EA Service is up for the challenge.

- Non Skid Coatings
- Secondary Containment
- Bridge Deck Sealing (non Skid)
- Chemical Resistant Flooring
- Concrete Sealing / Polishing
- Decorative non Decorative coatings
- Crack Repair / Pressure Injection
- Tank linings
- Concrete Overlays

## Photo Examples

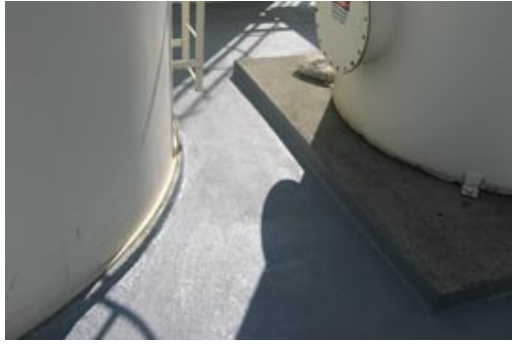

*Non Skid Coatings*



*Secondary Containment*



*Bridge Deck Sealing (non Skid)*



*Chemical Resistant Flooring*



*Concrete Sealing / Polishing*



*Decorative non Decorative coatings*



*Crack Repair / Pressure Injection*



*Tank linings*





*Concrete Overlays*

---

## **Painting & Blasting**

EA service Company is a professional company dedicated to preserving the life of your assets with high quality paints and coatings. We've earned a reputation as a premier painting and coating company with an extensive range of capabilities, qualified experience and equipment, with a superior work force.

EA Services provides painting, coatings along with Hydro and media blasting to the following Industries:

- Chemical & Refineries
- Pulp & Paper Industry
- City & Municipalities
- Food Processing Industry
- Public utilities
- OEM Market

EA Services are continuing to provide our customers with the latest coatings technology and service to exceed our customer's expectations.

## **Before and After Examples**



*Sand Filters Before*



*Sand Filters After*



*Cogen Stack Before*



*Cogen Stack After*



*Before*



After



After



Before



After



After

---

## Public Utilities



Providing energy to the world, power and cogeneration facilities are vital to our society. In today's ever-increasing need for energy with reduced environmental effects, power and cogeneration plants need increased protection and long term performance.

**EA Services provides** a wide variety of products to meet those requirements. Products that can provide maximum protection with minimal surface preparation, low odors, low VOC and fast cure time are in demand along with **expert recommendations**.

- Chemical Containments Coatings
  - Containment Repairs (Structural)
  - Crack Injection (Pressure Injection)
  - Concrete Overlays
  - Cooling Tower Containment Coatings
  - Warehouse Floors
- 

## Pulp & Paper



Protecting equipment and structures of the Pulp and Paper industry has dramatically changed over the past fifty years. Unplanned forced repairs cause expensive delays in production and can cost companies millions of dollars in revenues in just a few days.

Critical areas such as the "wet end" of the paper machines, liquor tanks, clarifiers, and bleach tanks must be kept in peak condition. Downtime must be kept to a minimum.

Safety is a key issue with anti-slip surfaces. These issues need to be taken in consideration along with service life when specifying a proper coatings system for the Pulp & Paper Industry.

**That is where EA services can help!**

- Chemical Containments (Acids / Caustics)
- Paper Machine Floors
- Concrete Overlays
- Non Skid Coatings
- Crack Repair / Pressure Injection for Structural Repairs
- Bathroom Floors
- Shower Floors (Color Quartz)
- Chemical Loading / Unloading Pads
- Tank Base Repair
- Office Floors (Flake / Color Quartz)

## **Before and After Examples**



*Concrete Overlays Before*



*Concrete Overlays After*



*Concrete Overlays Before*



*Concrete Overlays After*



*Tank Base Before*



*Tank Base After*



*PM Winder Floor After*



*PM Winder Floor After*

## **Bolt Tensioning Services**

EA Services has trained technicians and state of the art equipment for all your bolting needs . We offer hydraulic torque wrenches with  $\frac{1}{2}$ " to  $2\text{-}\frac{1}{4}$ " drives to cover  $\frac{1}{8}$ " through  $2\text{-}\frac{3}{4}$ " stud sizes as well as heavy hex size sockets & low clearance link tools. We offer stud tensioning equipment in all sizes and ultrasonic stress measuring for critical flange documentation. When studs are damaged and must be replaced, EA Services will machine out old studs, preserving the internal threads if possible or oversize and rethread the hole if required. We can supply hands on labor & equipment, or technical support to assist your craft in using the equipment.

## **EA SERVICES PROVIDES:**

- Hydraulic Torque Wrenches  $\frac{1}{2}$ " Through  $2\text{-}\frac{1}{4}$ " Stud Sizes  $\frac{1}{8}$ " Through  $2\text{-}\frac{3}{4}$ " Heavy Hex Sizes Socket & Low Clearance Link
- Bolt Tensioning Services  $\frac{3}{4}$ " through  $2\frac{1}{2}$ " stud diameter Fit ANSI and API flanges  $90\%$  and  $100\%$  tensioning kits Up to  $21,700$  PSI
- Stub Removal Services Stud extraction (drilling) Drilling of holes for oversized studs Tapping of stud holes
- Nut Splitting Services  $\frac{1}{2}$ " through  $2\text{-}\frac{3}{4}$ " nut sizes



*Assembling flanges with low clearance hydraulic torque wrench*



*Assembling flanges using hydraulic torque wrench*



*Assembling flanges using hydraulic tensioning equipment*



*Low clearance model hydraulic torque wrench*



